

ENERGY = -40.3 seq1

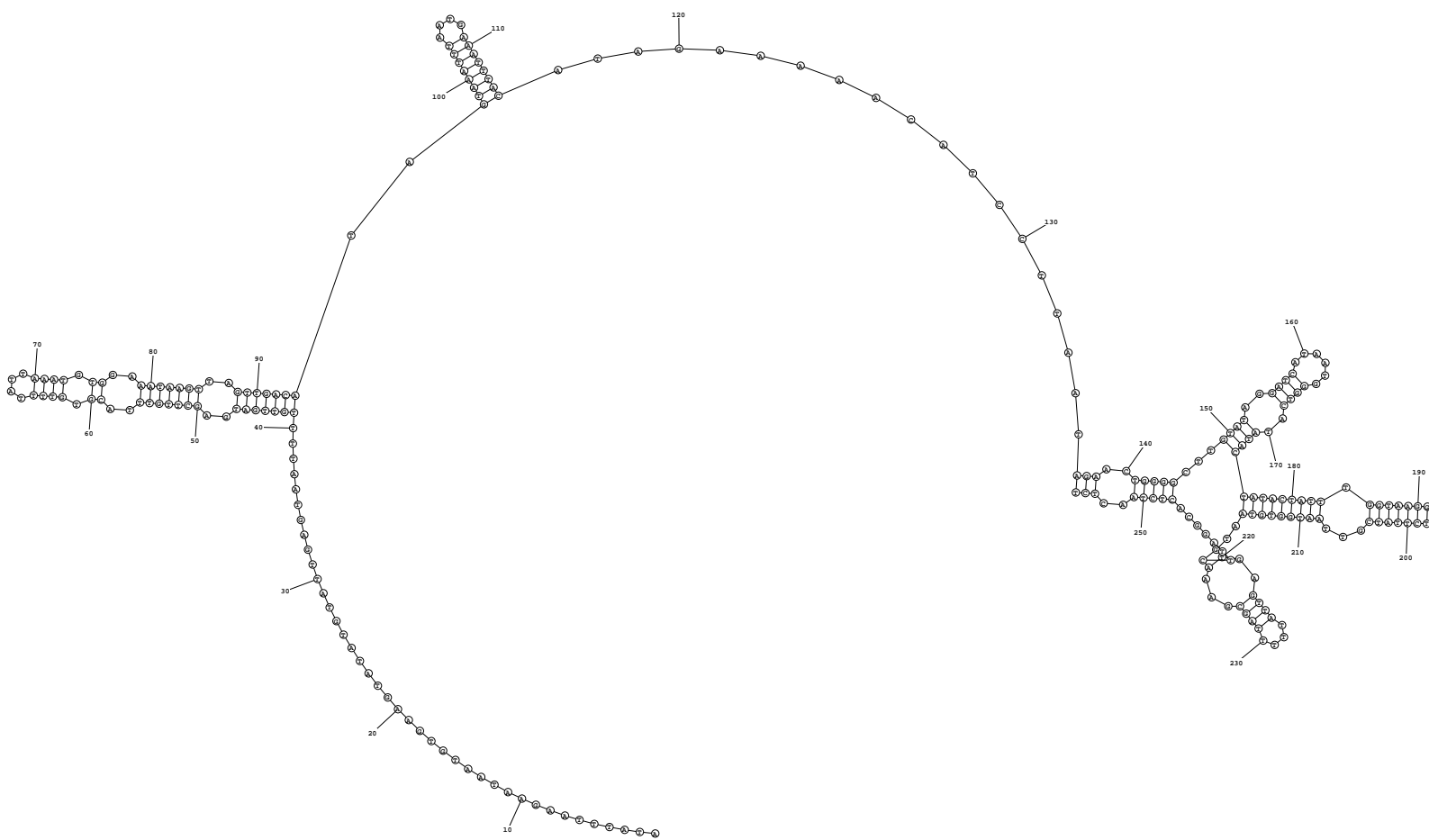

ENERGY = -40.3 seq1

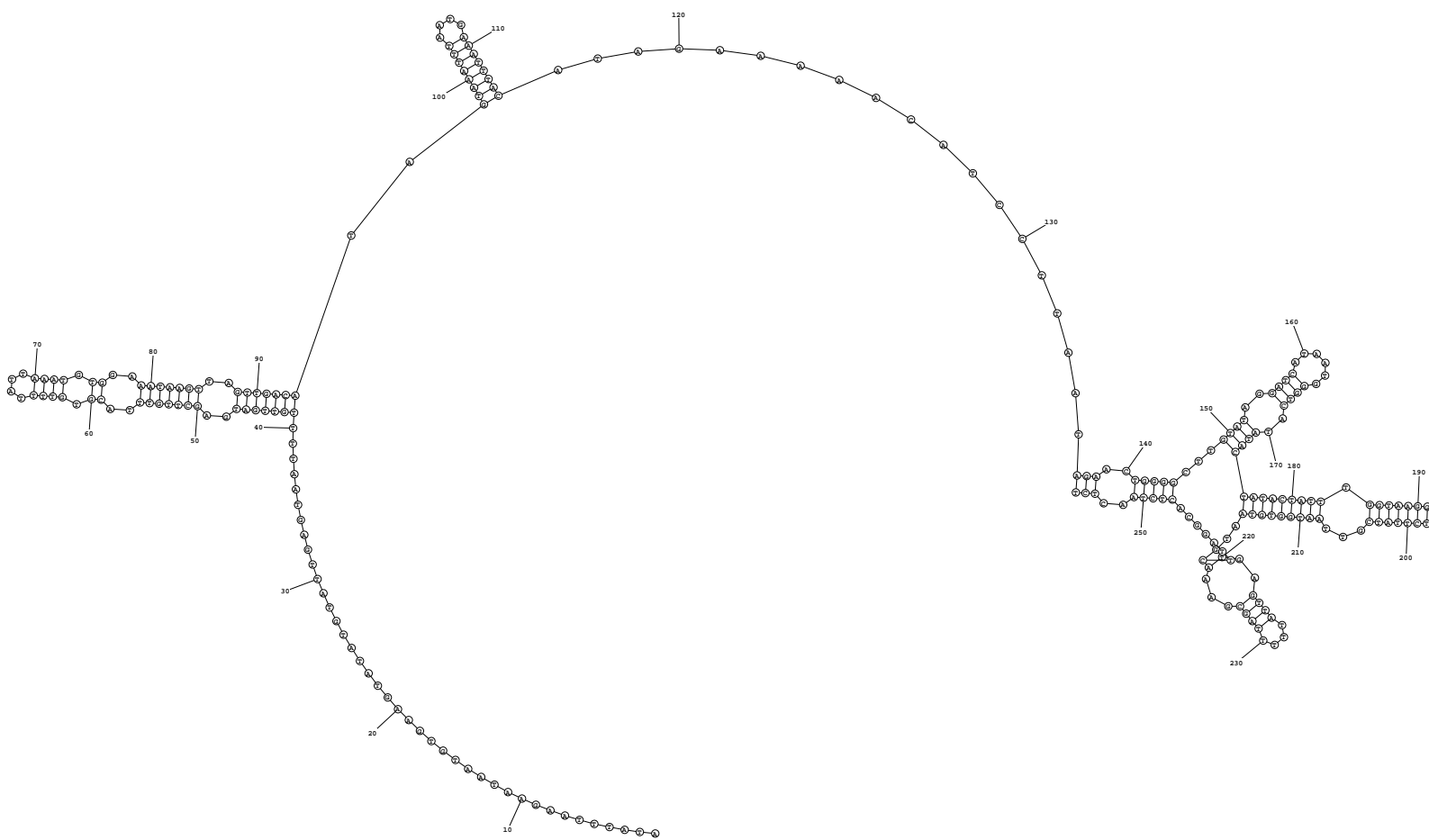

ENERGY = -40.3 seq1

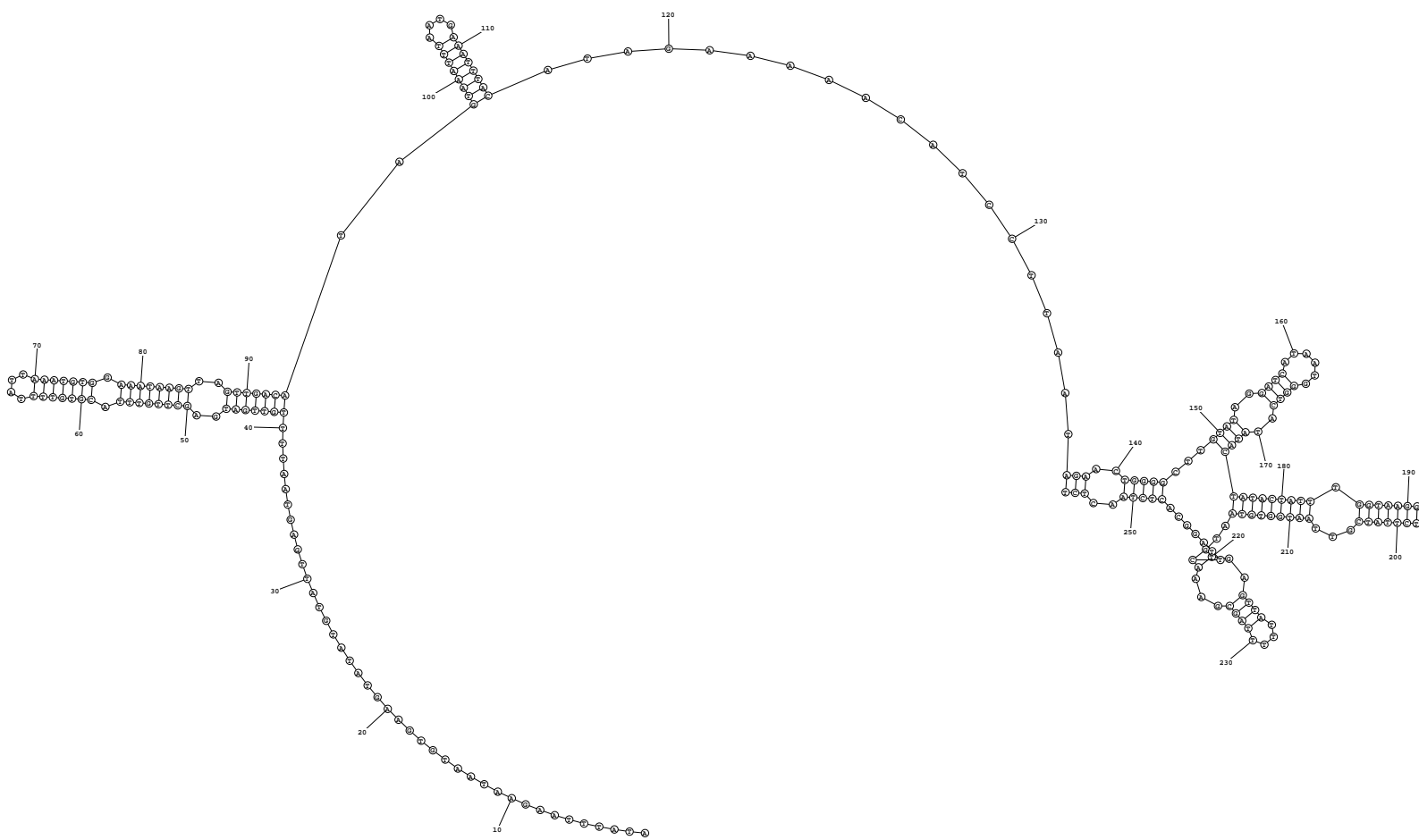

ENERGY = -40.0 seq1

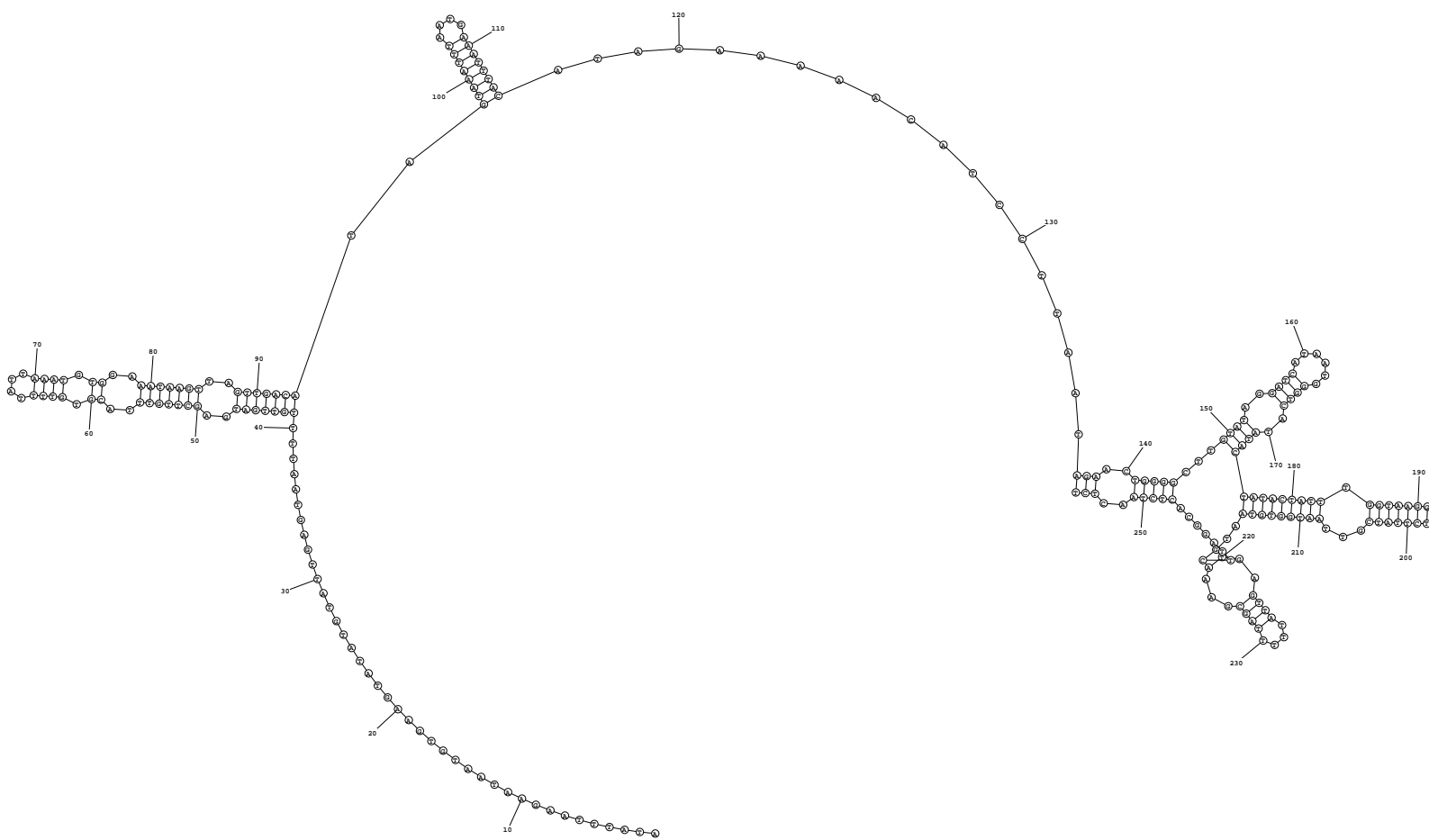

ENERGY = -40.3 seq1

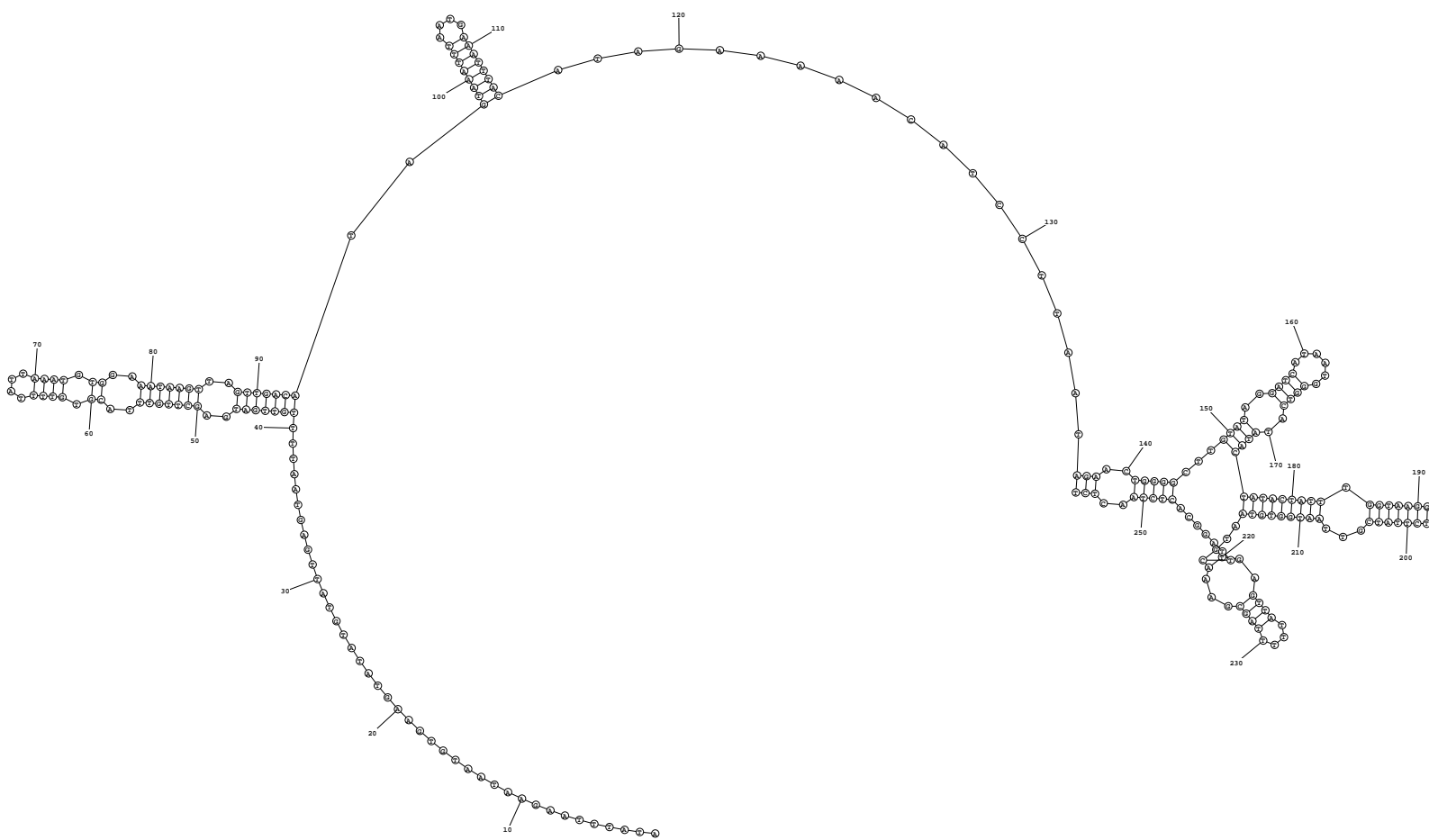

ENERGY = -40.3 seq1

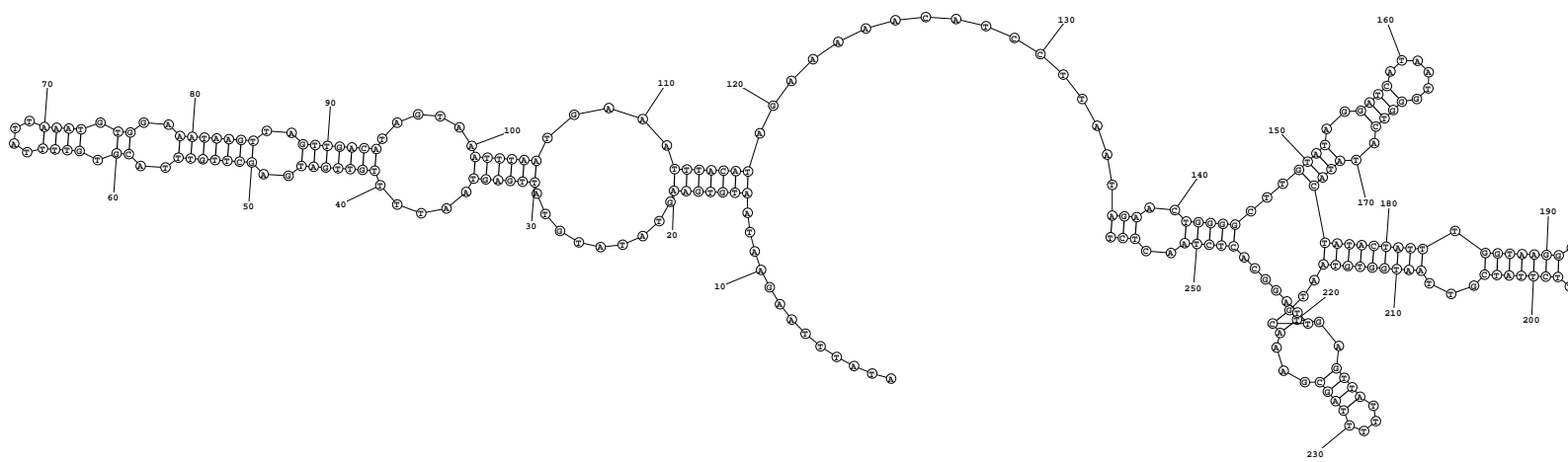

ENERGY = -39.8 seq1

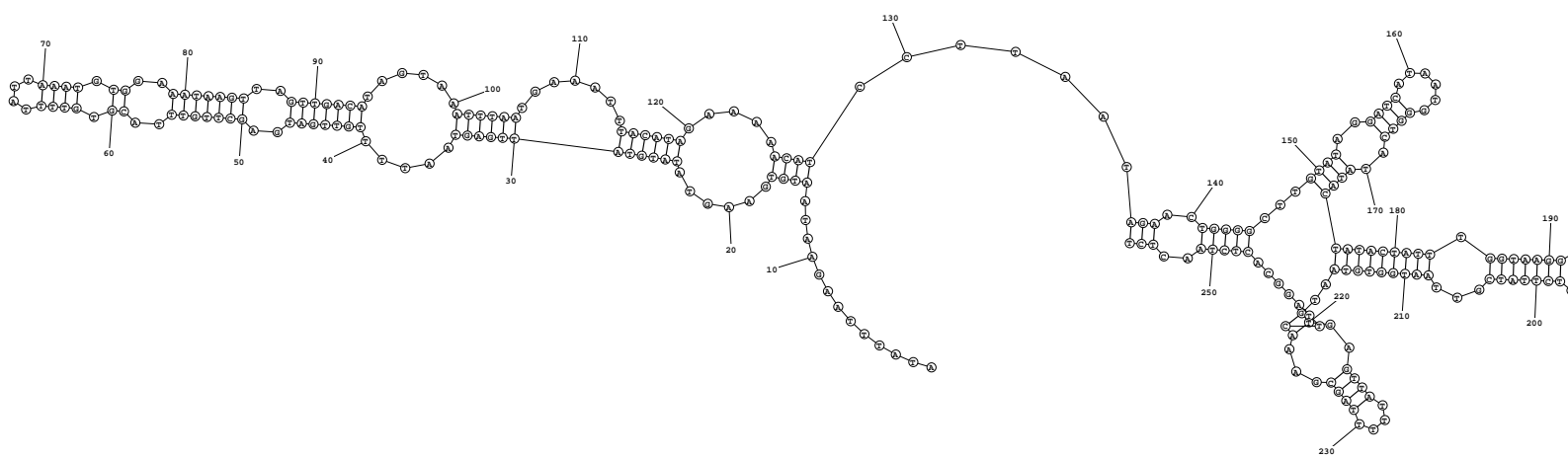

ENERGY = -41.8 seq1

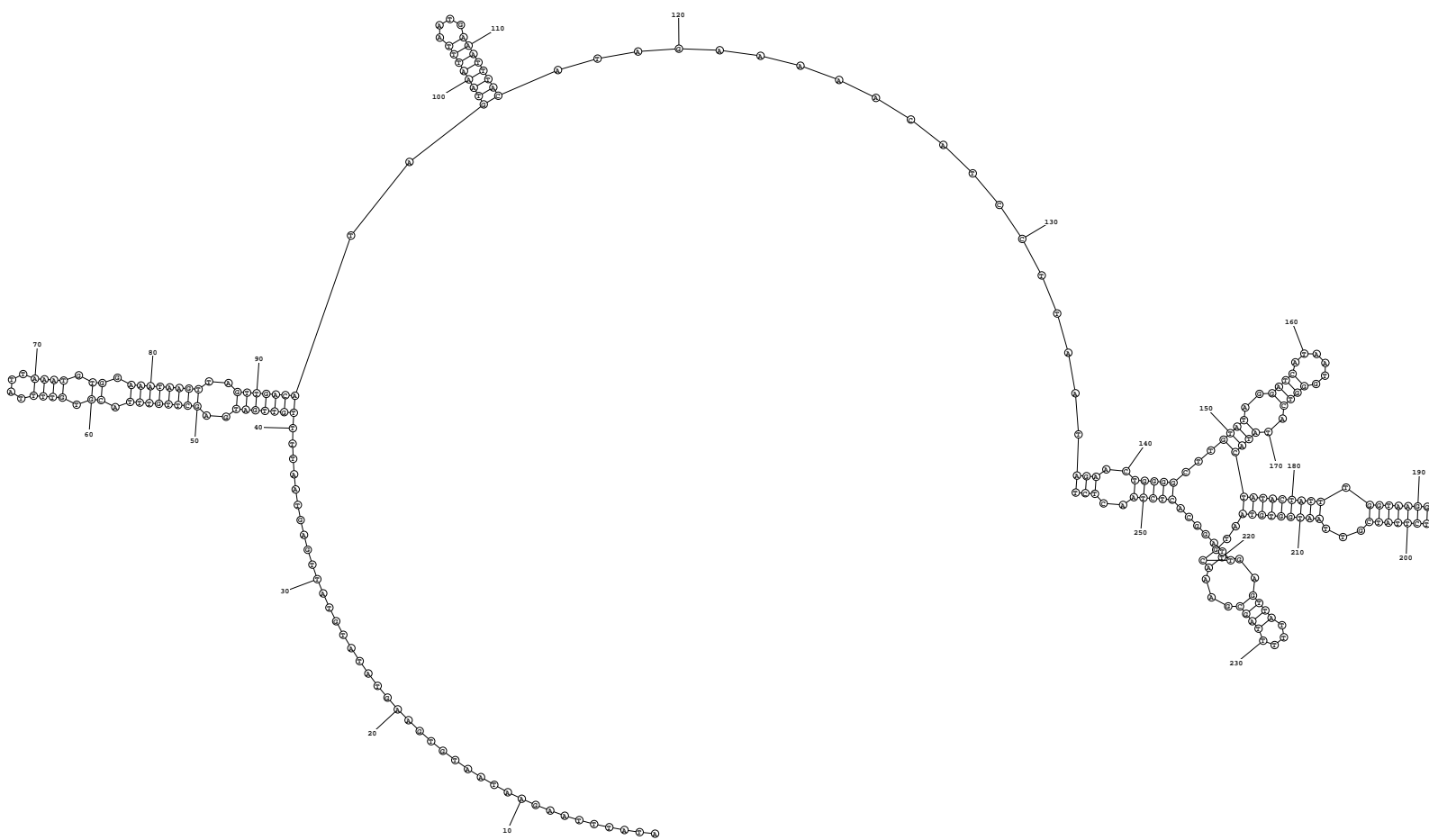

ENERGY = -39.7 seq1

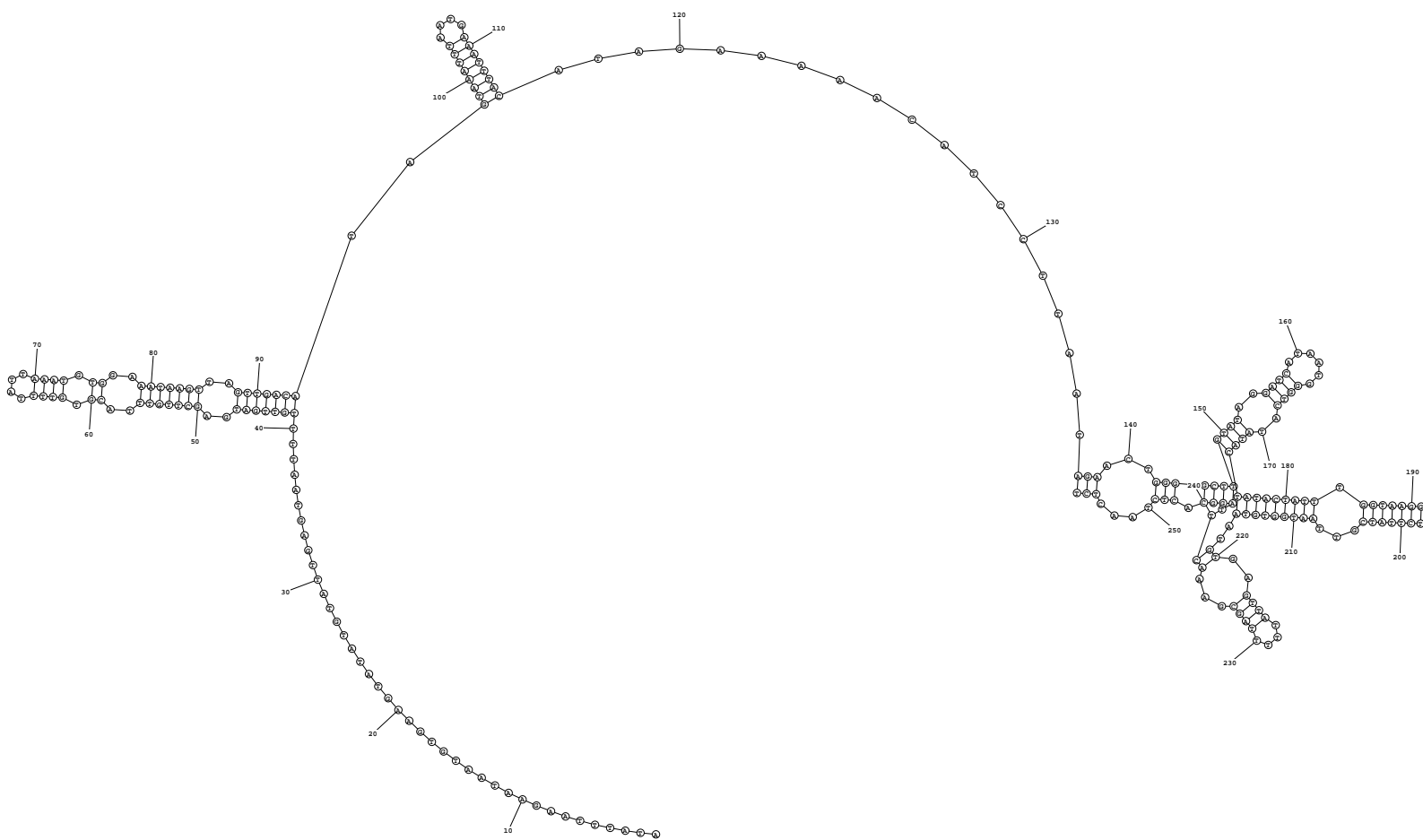

ENERGY = -43.0 seq1

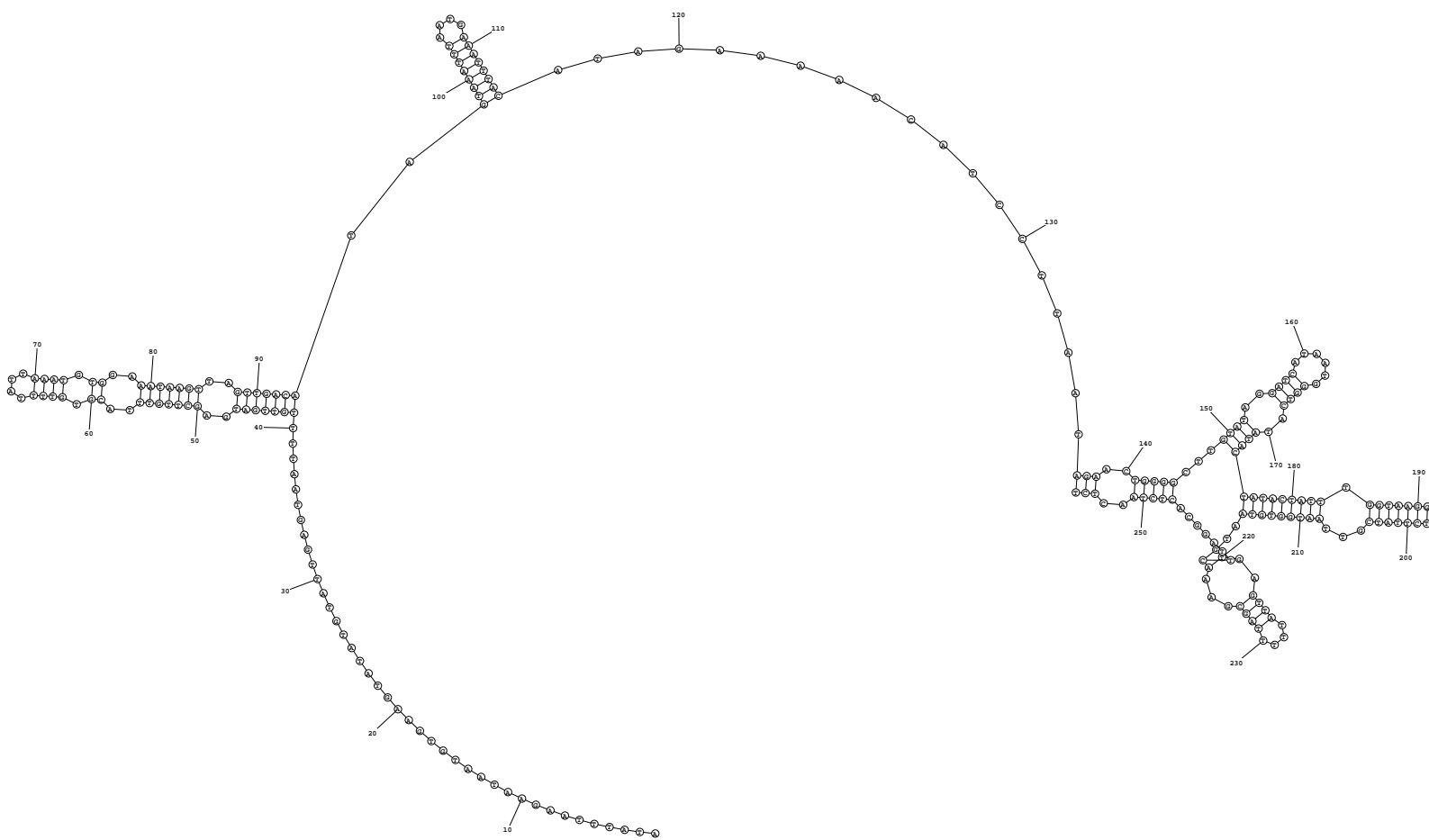

ENERGY = -40.3 seq1

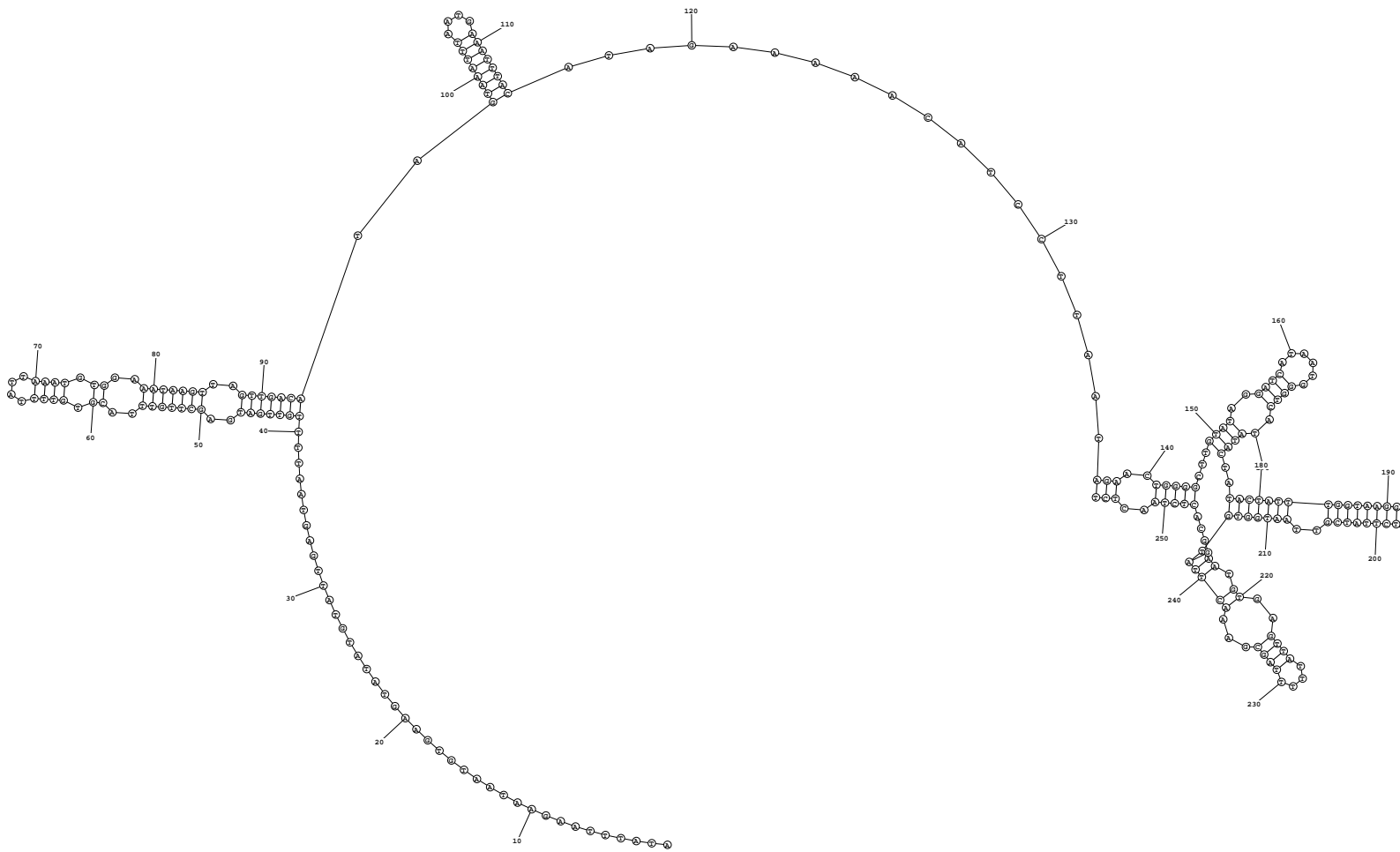

ENERGY = -37.8 seq1

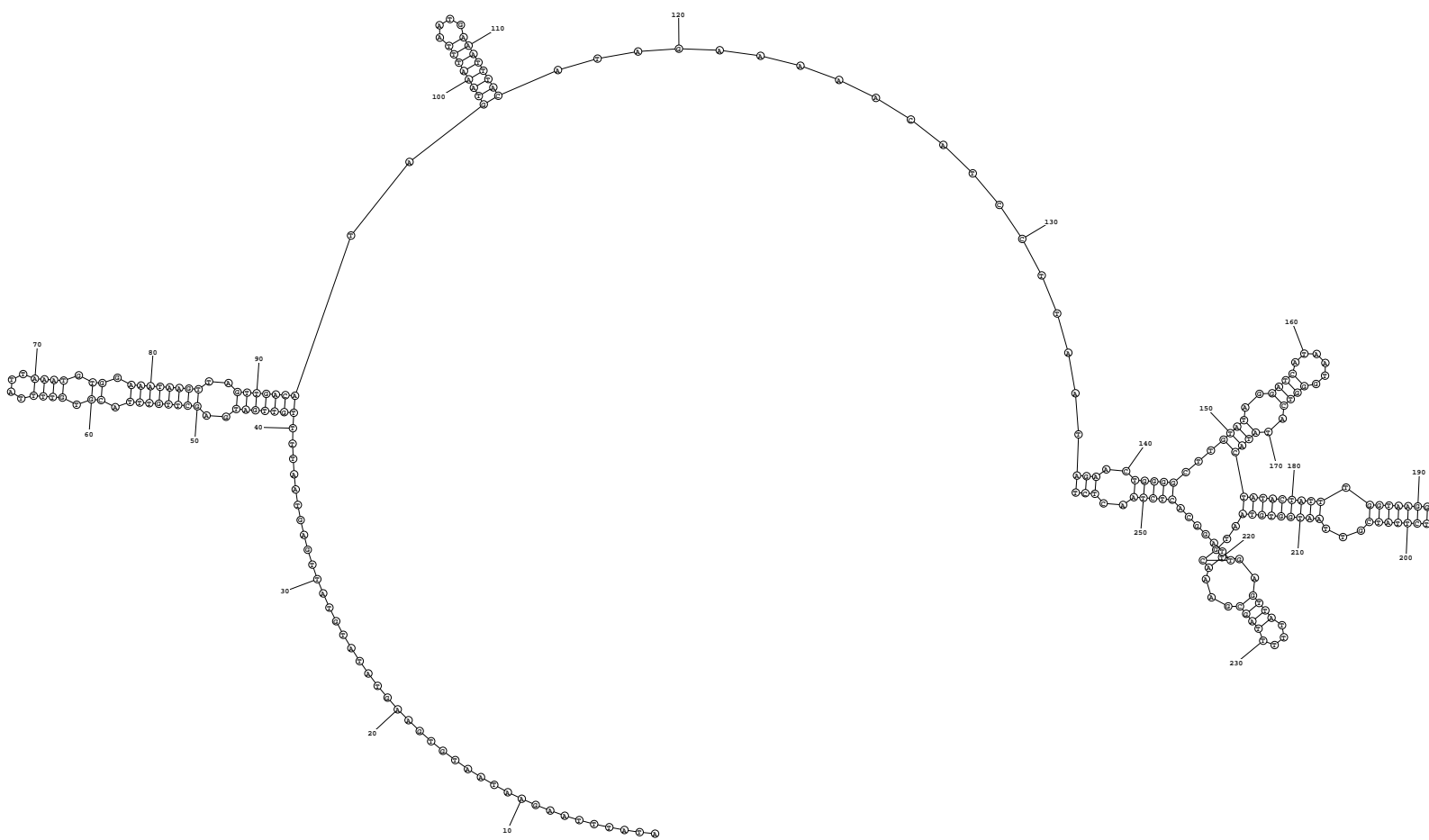

ENERGY = -39.7 seq1

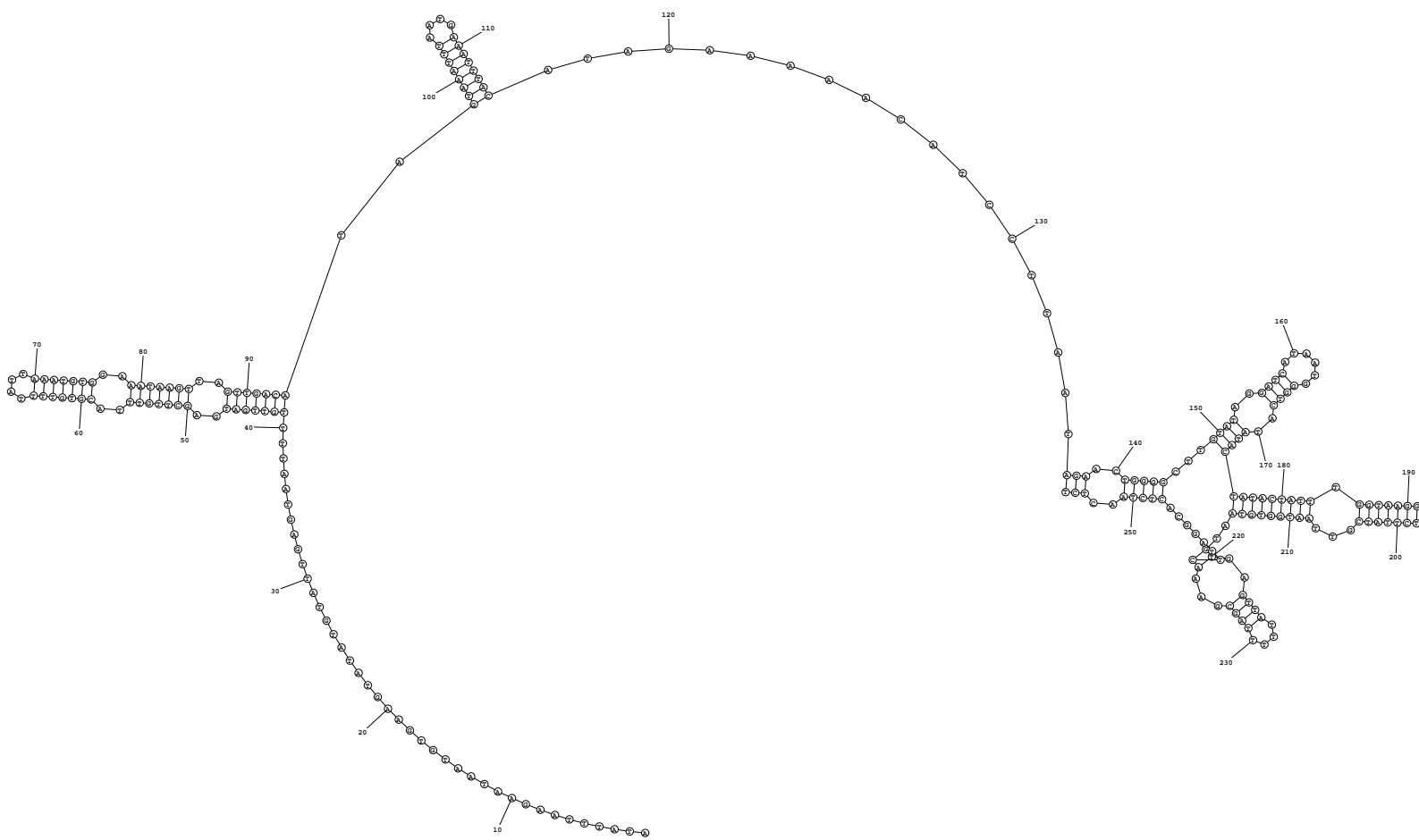

ENERGY = -40.6 seq1

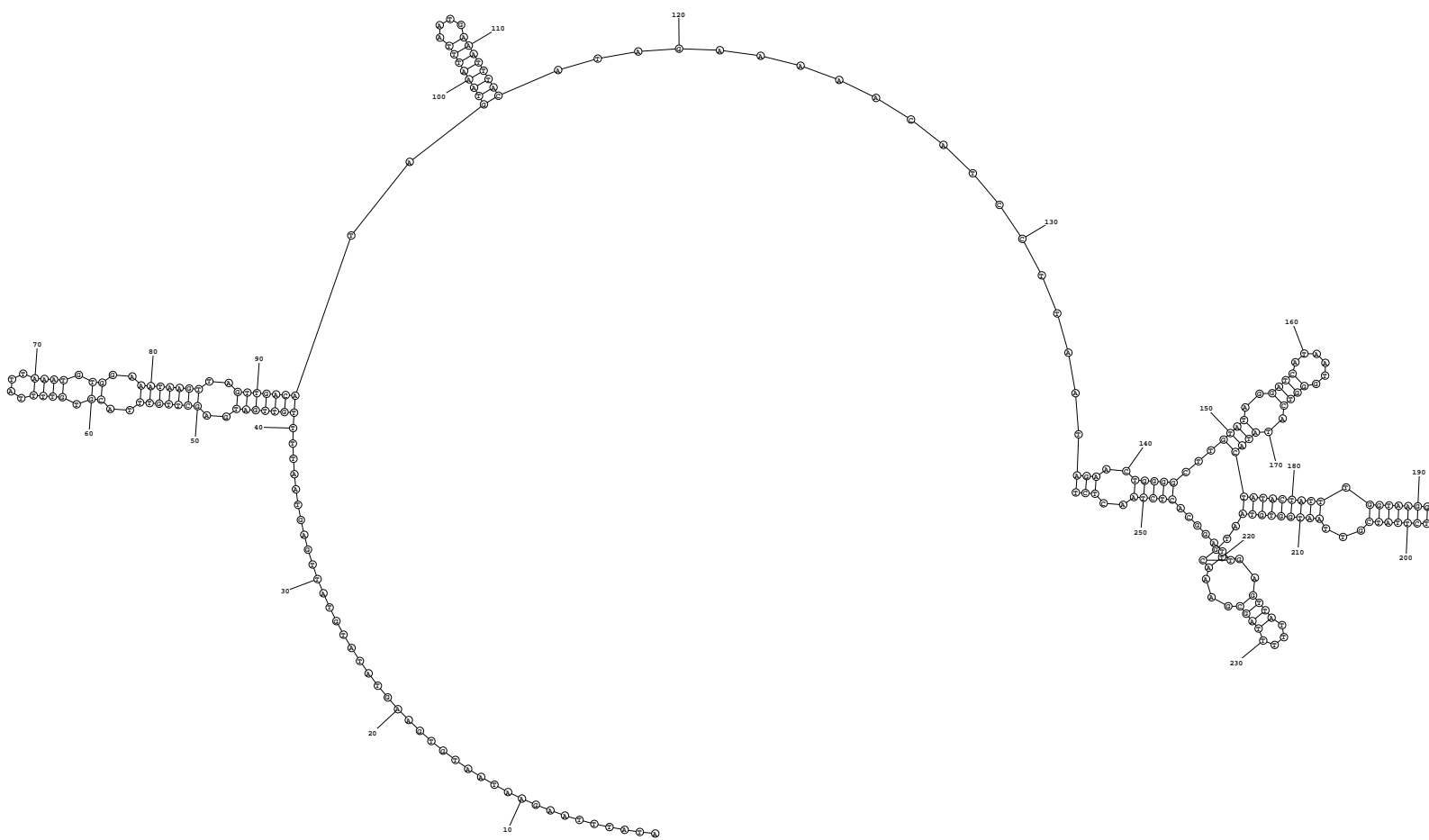

ENERGY = -40.3 seq1

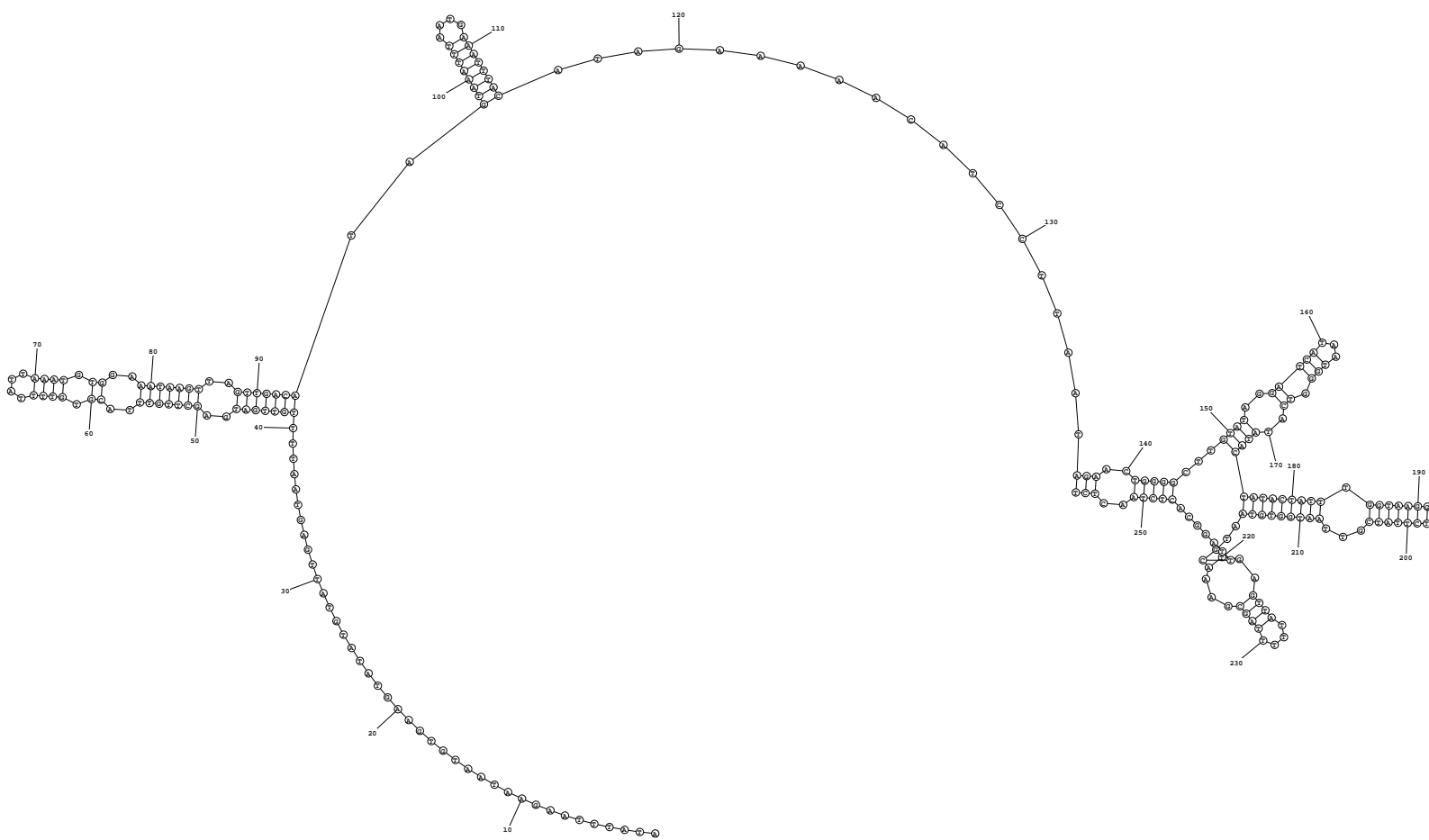

ENERGY = -37.4 seq1

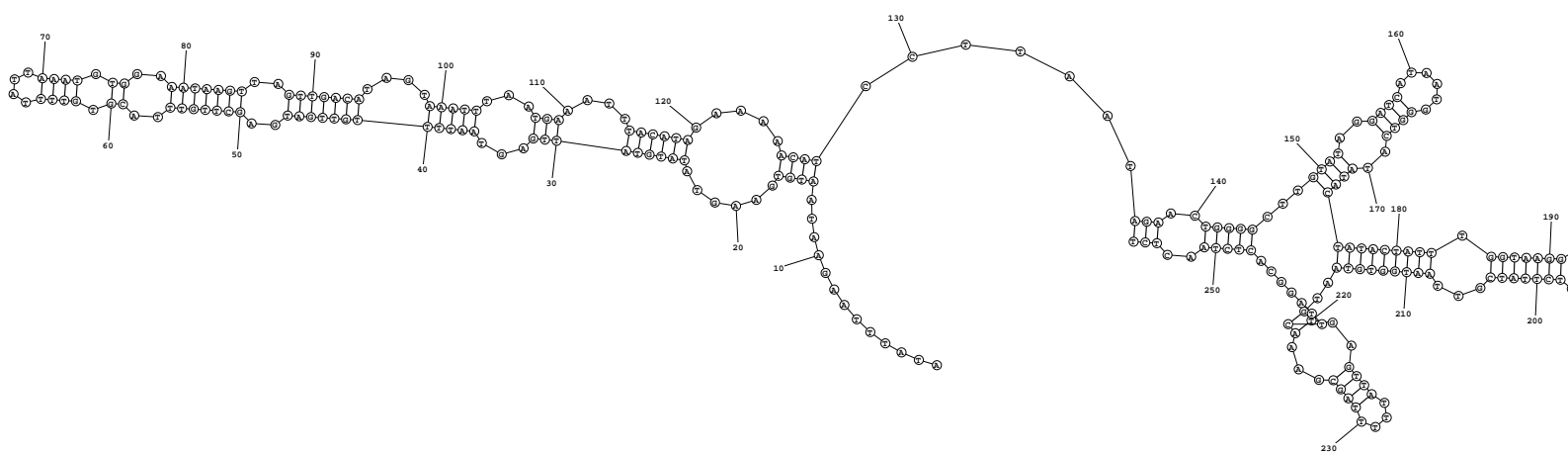

ENERGY = -39.0 seq1

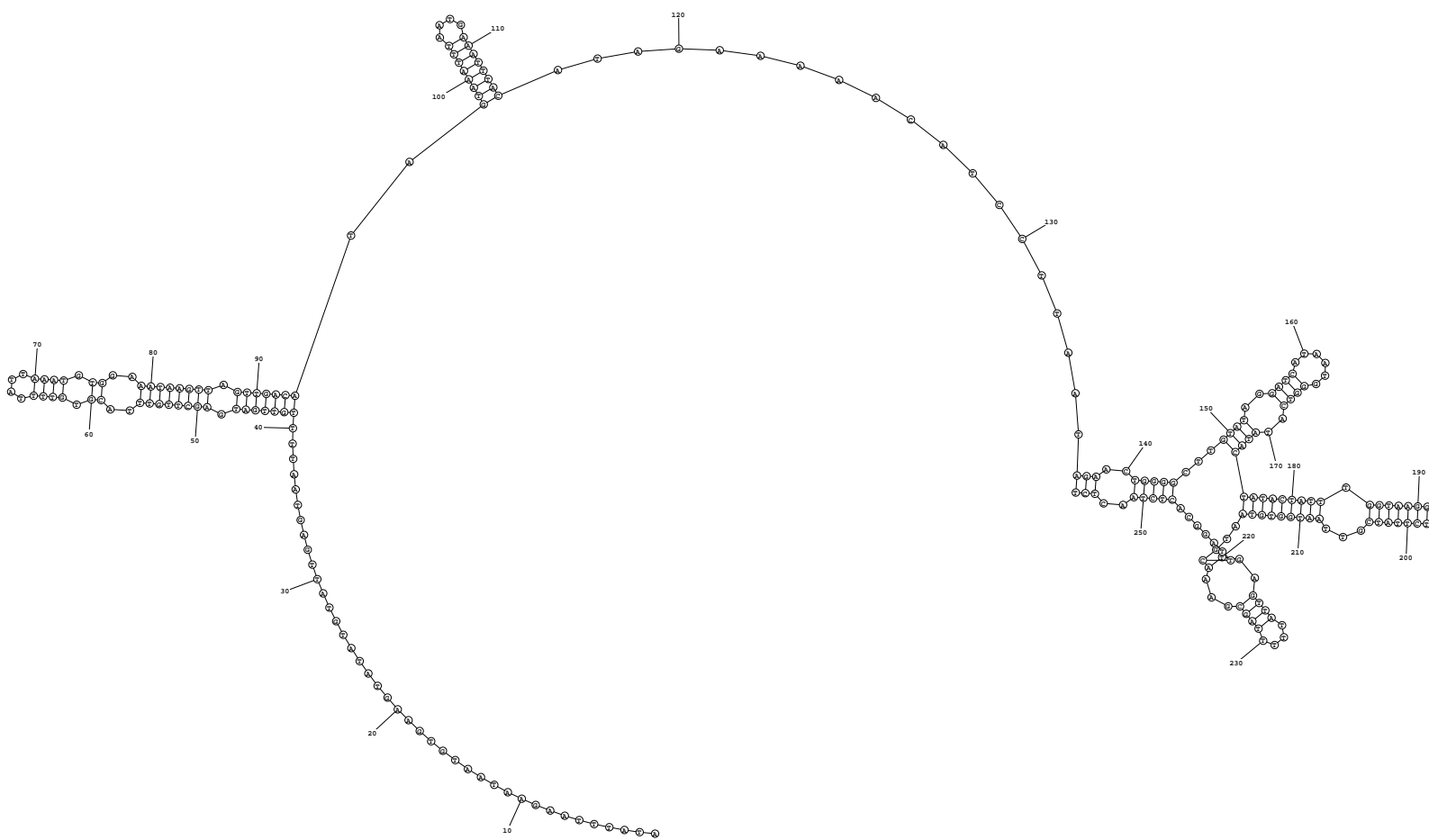

ENERGY = -40.4 seq1

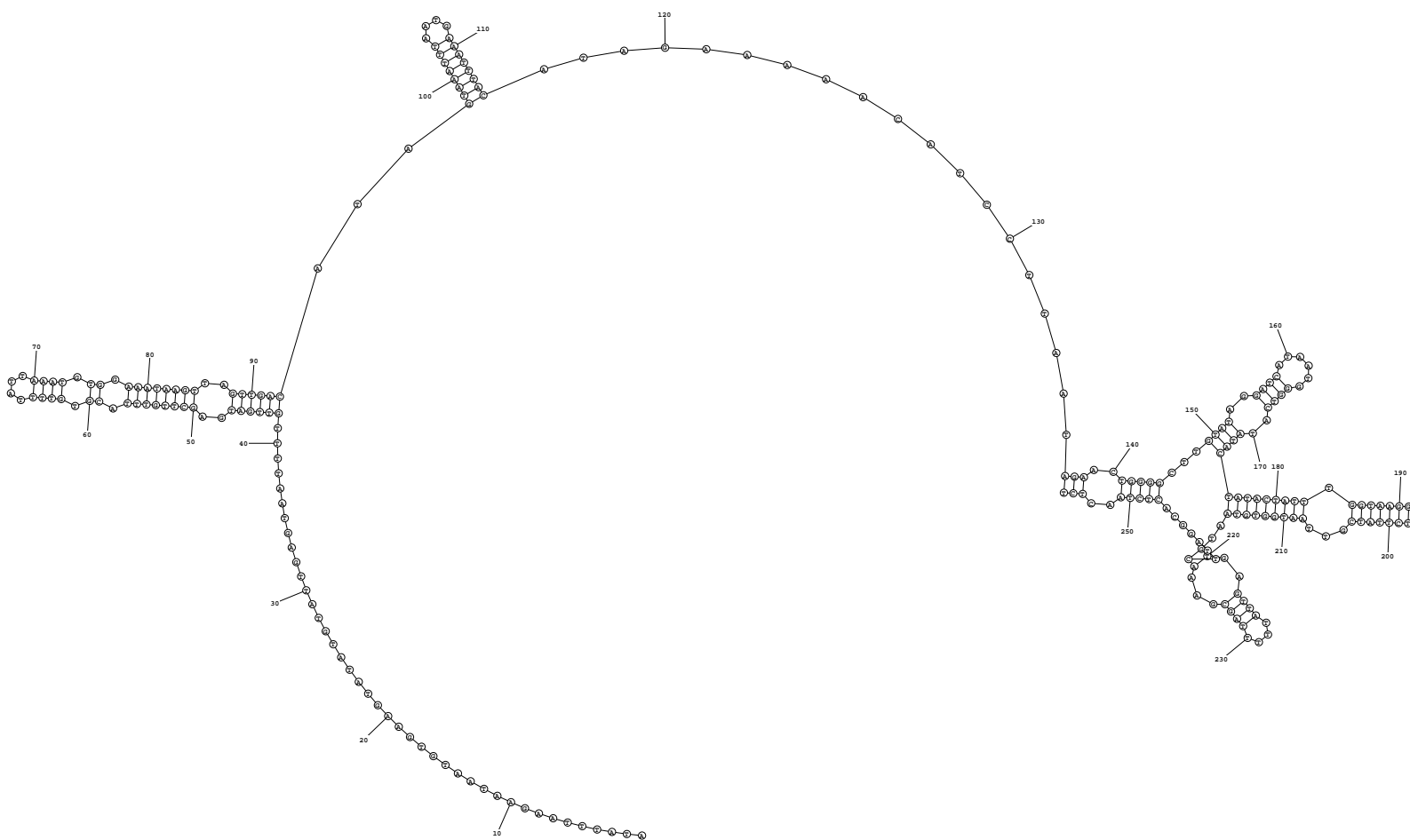

ENERGY = -39.0 seq1

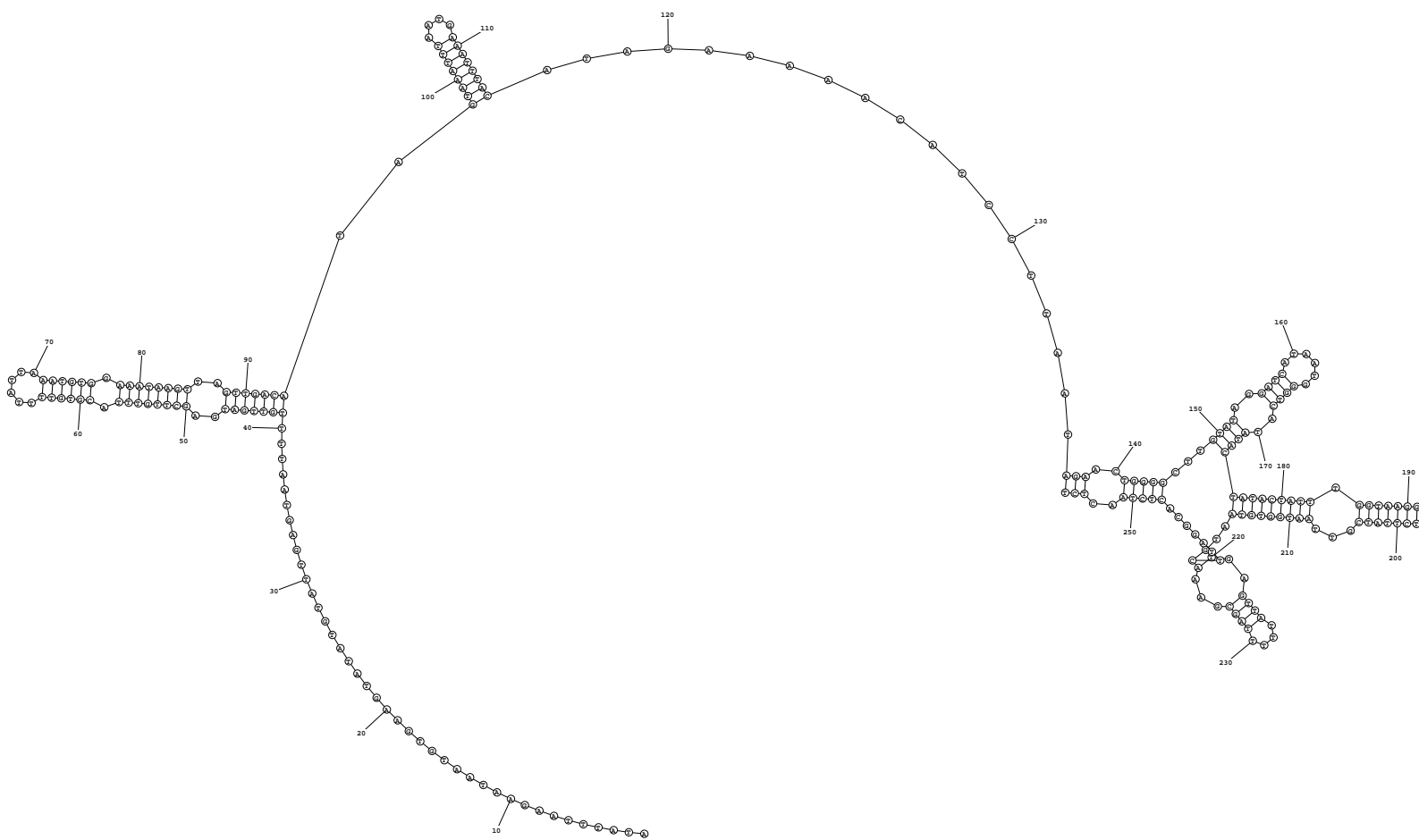

ENERGY = -38.6 seq1